

Adapter Plus[®]

Improve curving, rolling resistance and wear

Key Facts

- Approved for use on 100 ton Motion Control[®] and 100 ton S-2-HD[®] M-976 Bogies
- Unlike other designs, there are no special side frame modifications required
- Provides superior curving performance with passive steering
- Available in 6 x 11, 6-1/2 x 9, 6-1/2 x 12, 7 x 12 and international designs
- Customers have experienced over 1,000,000 service miles
- Nearly two decades of field service with hundreds of thousands of carsets operating today
- Eliminates side frame pedestal roof wear and thrust lug wear
- Eliminates the need for pedestal roof wear plates
- Wheel life extended with reduced lateral force in curves
- Easy retrofit to all existing S-2-HD[®] split wedge or Super Service Ride Master[®] Trucks
- Eliminates bearing adapter wear and metal-to-metal contact
- Improves roller bearing life with reduced lateral forces and vertical impacts

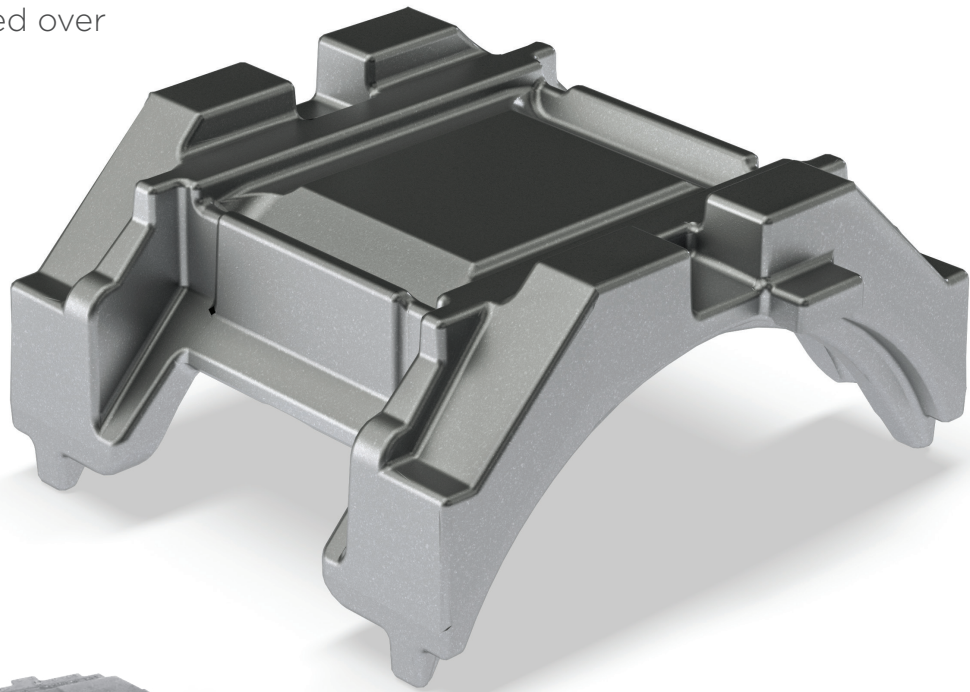

Standard Adapter

Key Facts

- Tested and approved AAR designs
- Available in a variety of sizes and heat treat specifications
- Fits standard AAR pedestals

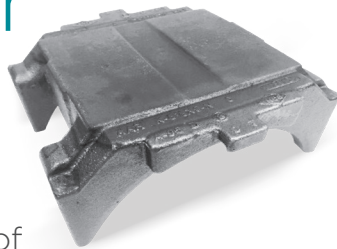

Amsted Rail[®]

Adapter Descriptions

Adapter Description	Journal Size	Heat Treat Specification	Part #
Standard AAR Adapter	5 1/2 X 10	No Heat Treat	A50
		Hardened Crown Only	A50C
		Hardened Thrust Shoulders Only	A50T
		Hardened Crown and Thrust Shoulders	A50CT
	6 X 11	No Heat Treat	A70
		Hardened Crown Only	A70C
		Hardened Thrust Shoulders Only	A70T
		Hardened Crown and Thrust Shoulders	A70CT
	6 1/2 X 9	No Heat Treat	A95
		Hardened Crown Only	A95C
		Hardened Thrust Shoulders Only	A95T
		Hardened Crown and Thrust Shoulders	A95CT
	6 1/2 X 12	No Heat Treat	A90
		Hardened Crown Only	A90C
		Hardened Thrust Shoulders Only	A90T
		Hardened Crown and Thrust Shoulders	A90CT
7 X 12	No Heat Treat	A125	
	Hardened Crown Only	A125C	
	Hardened Thrust Shoulders Only	A125T	
	Hardened Crown and Thrust Shoulders	A125CT	
Adapter Plus® E/D	5 1/2 X 10	Hardened Thrust Shoulders Only	17910
Adapter Plus®	6 X 11	Hardened Thrust Shoulders Only	10472
AR-1® Ride Control®		Hardened Thrust Shoulders Only	17860
Special Reverse Crown Adapter		Hardened Crown Only	50602
Special 1" Raised Head Reverse Crown Adapter		Hardened Crown Only	51713
Adapter Plus®	6 1/2 X 9	Hardened Thrust Shoulders Only	1771
Special Reverse Crown Adapter		Hardened Crown Only	53142
Swing Motion® Adapter Plus®		Hardened Thrust Shoulders Only	10523A
AR-1® Ride Control®		Hardened Thrust Shoulders Only	98-1-10669
Adapter Plus® for Side Frames with Raised Pedestal Option		Hardened Thrust Shoulders Only	98-1-10729
Adapter Plus®	6 1/2 X 12	Hardened Thrust Shoulders Only	1233
Special 1 9/32" Raised Head Adapter		Hardened Crown Only	17911-1
Swing Motion® Reverse Crown	7 X 9	Hardened Crown Only	G316RHC
Adapter Plus®	7 X 12	Hardened Thrust Shoulders Only	10458
Bearing Adapter Pad (Adapter Plus®)			10471 (Class E)
			10454 (Class F)
			10457 (Class G)
			10454 (Class K)
			10601 (Class K)

